

**Feature:**

- Up to 3000 in.lb [350Nm].
- Clutch for manual adjustments.
- Maintenance free.
- Fail safe (battery backup) (on model 010 & 030).
- Auxiliary switches (on model 020 & 030).

UM000-30
UM020-30
UM010-30
UM030-30
WM000-60
WM020-60
WM010-60
WM030-60

Technical Data	UM000-30	UM020-30	UM010-30	UM030-30	WM000-60	WM020-60	WM010-60	WM030-60
Auxiliary switches	No	Yes (2)	No	Yes (2)	No	Yes (2)	No	Yes (2)
Fail safe	No		Yes		No		Yes	
Torque	1800 in.lb. [200 Nm] at rated voltage				3000 in.lb. [350 Nm] at rated voltage			
Running time through 90°	30 sec.				60 sec.			
Feedback	4 to 20 mA or 2 to 10 VDC adjustable							
Power consumption	100 VA							
Power supply	22 to 26 VAC or 28 to 32 VDC							
Electrical connection	18 AWG [0.8 mm ²] minimum							
Inlet bushing	3 inlet bushing of 7/8 in [22.2 mm]							
Control signal	4 wire / Analog							
Angle of rotation	0 to 110 degrees, electronically adjustable (factory set with 110° stroke)							
Direction of rotation	Reversible, Clockwise (CW) or Counterclockwise (CCW) (factory set with CW direction)							
Ambient temperature	0°F to +122°F [-18° C to +50° C]							
Storage temperature	-22°F to +122°F [-30° C to +50° C]							
Relative Humidity	5 to 95 % non condensing.							
Weight	26 lbs. [12 kg]							
Warning: Do not press the clutch when actuator is powered								

Dimensions

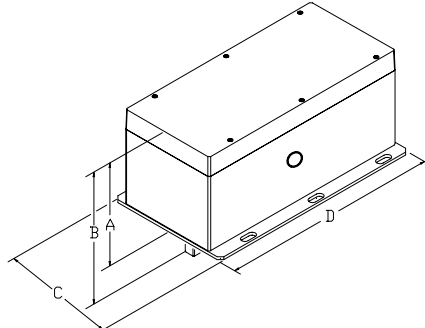

Dimension	Inches	Metric (mm)
A	6.75	169.4
B	7.95	201.9
C	7.85	199.4
D	14.45	367.0

Caution

We strongly recommend that all neptronic® products be wired to a separate transformer and that transformer shall service only neptronic® products. This precaution will prevent interference with, and/or possible damage to incompatible equipment.
 When multiple actuators are wired on a single transformer, polarity must be observed. Long wiring runs create voltage drop which may affect the actuator performance.



Exploded view

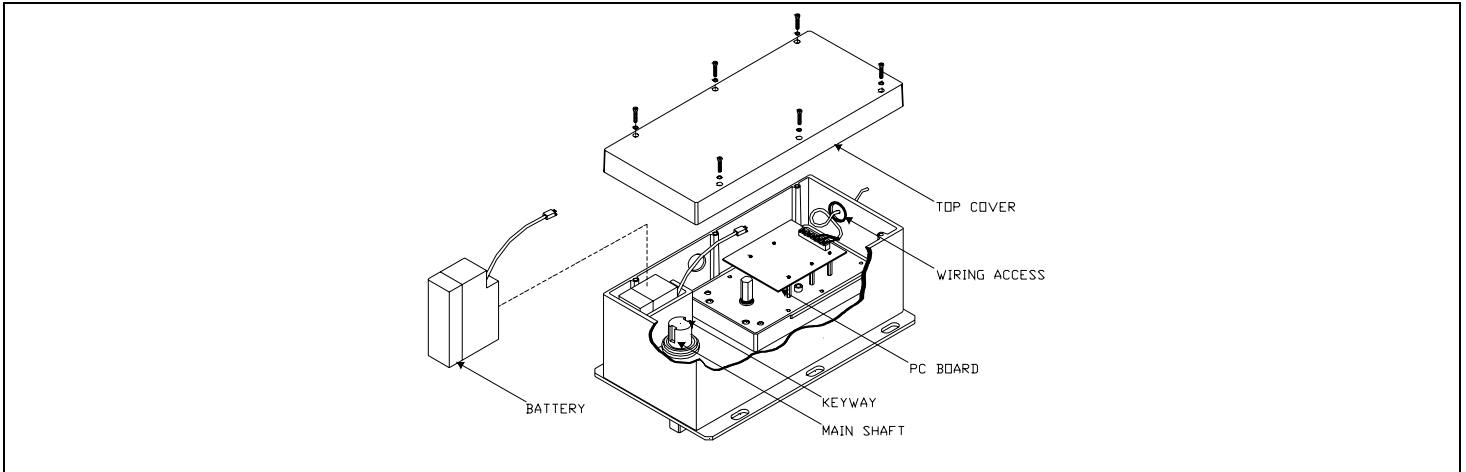

Wiring Diagrams

Analog

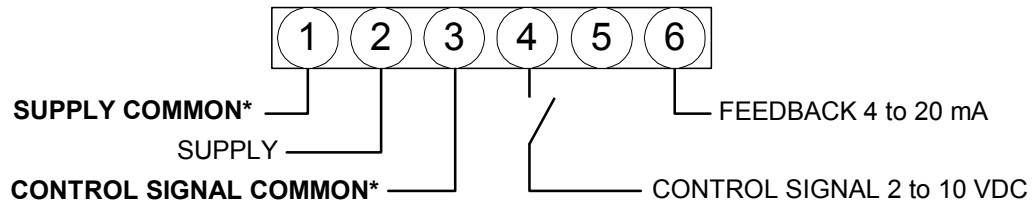

***CONTROL SIGNAL COMMON MUST BE DIFFERENT THAN SUPPLY COMMON.**

For 4 to 20 mA control signal

Connect one of the supplied 500 ohm resistors between pins 3 and 4.

For 2 to 10 VDC output feedback

For any of above wiring configurations, connect one of the supplied 500 ohm resistors between pins 1 and 6.

PC Board

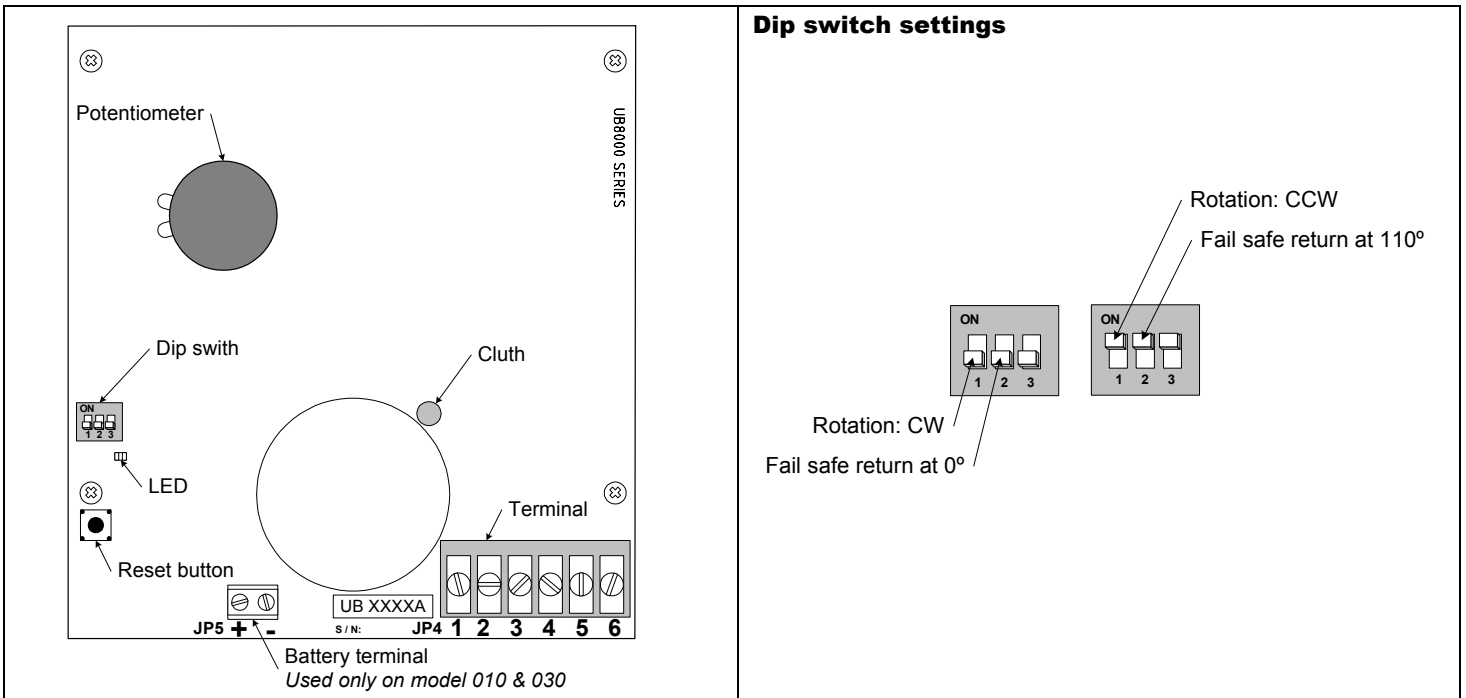

Dip switch settings

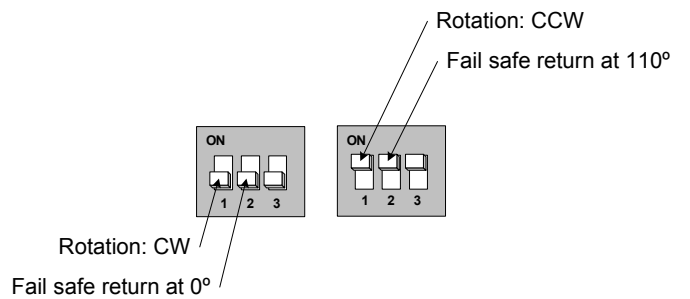

Stroke adjustment

1. Remove power and put all dip switches "OFF". (factory preset).
2. Apply power and **wait 10 seconds**
3. Press and release the reset button to start the auto-stroke process.
The LED should be illuminated.
 - First option:
The actuator will then travel in both directions to find it's limit and position itself according to the demand.
The LED will extinguish, the process is complete.
 - Second option:
When the desired end position is reached, press and release the reset button. The actuator will now return back to its original position. (you can also press and release the reset button when It's reaches the original position)
The LED will extinguish, the process is complete.

Feedback selection (CCW direction)

To select CCW direction put switch No1 "ON".

You can program the feedback control.

If switch No3 is "OFF":

The feedback control is automatically reverse to 4 to 20 mA for 110 to 0 degrees.

If switch No3 is "ON":

The feedback control is to 20 to 4 mA for 110 to 0 degrees.

Zero and span calibration

1. Remove power and put all dip switches "OFF". (factory preset).
2. Apply power and, **within 10 seconds** press and hold the reset button until the LED blinks once.
The Zero and span calibration process then start.
3. Release the reset button. The LED is now constantly illuminated.
4. Apply new minimum voltage.
It can be any value between 0 to 7 VDC, with an external 0 to 10 volt supply (ex: MEP).
5. Press and release the reset button to memorize the new minimum voltage. The LED blinks once.
6. Apply new maximum voltage.
It can be any value between 3 to 10 VDC, this value should be greater than the new minimum value.
7. Press and release the reset button to memorize the new maximum voltage. The LED blinks once.
The Zero and span calibration process is complete.

Note: To reset zero and span to 2 to 10 VDC (factory value), please proceed as follow.

1. Remove power and put all dip switches "OFF". (factory preset).
2. Apply power and, **within 10 seconds**, press and release the reset button. The LED should be blinking.
3. Move switch **No3** "ON" and then "OFF".

