

**Feature:**

- Clutch for manual adjustments.
- Maintenance free.
- Position indicator.
- Fail safe by *Enerdrive System*¹ (on model 3060, 3080, 5060 & 5080).
- Auxiliary switches (on model 3021, 3080, 5021 & 5080).

New Number

TBTF3000A	TT000F
TBTF3021A	TT020F
TBTF3060A	TT060F
TBTF3080A	TT080F
RBTF5000A	RT000F
RBTF5021A	RT020F
RBTF5060A	RT060F
RBTF5080A	RT080F

Technical Data	TBTF3000A <i>TT000F</i>	TBTF3021A <i>TT020F</i>	TBTF3060A <i>TT060F</i>	TBTF3080A <i>TT080F</i>	RBTF5000A <i>RT000F</i>	RBTF5021A <i>RT020F</i>	RBTF5060A <i>RT060F</i>	RBTF5080A <i>RT080F</i>
Auxiliary switches	No	Yes(2)	No	Yes (2)	No	Yes(2)	No	Yes (2)
Fail safe - Enerdrive	No		Yes		No		Yes	
Power consumption	10 VA		24 VA Peak, 10 VA		18 VA		40 VA Peak, 18 VA	
Control signal	3 wire / 2 position, 3 wire / 3 point floating		2 wire / 2 position, 4 wire / 3 point floating		3 wire / 2 position, 3 wire / 3 point floating		2 wire / 2 position, 4 wire / 3 point floating	
Weight	4.5 lbs. [2 kg]				7 lbs. [3.2 kg]			
Torque	120 in.lb. [13.5 Nm] at rated voltage				240 in.lb. [27 Nm] at rated voltage			
Running time through 90°	20 to 30 sec Torque depending							
Power supply	22 to 26 VAC or 28 to 32 VDC							
Electrical connection	18 AWG [0.8 mm ²] minimum							
Inlet bushing	2 inlet bushing of 7/8 in [22.2 mm]							
Angle of rotation	0 to 90 degrees, electronically adjustable (factory set with 90° stroke)							
Direction of rotation	Reversible, Clockwise (CW) or Counterclockwise (CCW) (factory set with CW direction)							
Ambient temperature	0°F to +122°F [-18° C to +50° C]							
Storage temperature	-22°F to +122°F [-30° C to +50° C]							
Relative Humidity	5 to 95 % non condensing.							

Warning: Do not press the clutch when actuator is powered

Dimensions

Dimension	Inches	Metric (mm)
A	5.20	132.1
B	1.33	33.8
C	9.13	231.9
D	3.55	90.2

Caution

We strongly recommend that all neptronic® products be wired to a separate transformer and that transformer shall service only neptronic® products. This precaution will prevent interference with, and/or possible damage to incompatible equipment.

When multiple actuators are wired on a single transformer, polarity must be observed. Long wiring runs create voltage drop which may affect the actuator performance.

¹ Enerdrive System U.S.A. Patent #5,278,454



Mechanical installation

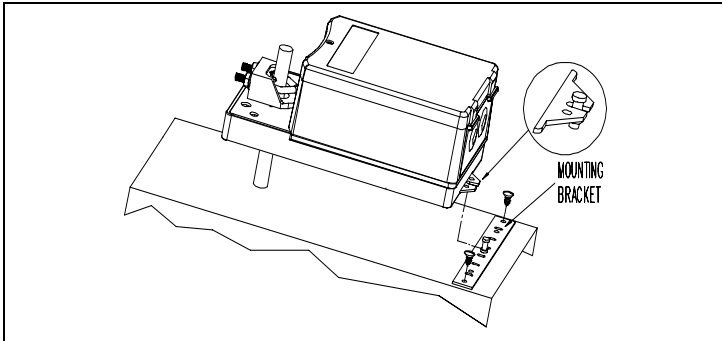

1. Manually close the damper blades and positioned the actuator at 0° or 90°.
2. Slide the actuator onto the shaft.
3. Tighten the nuts on the “U” bolt to the shaft with a 10mm wrench to a torque of 150 in.lb. [17 Nm].
4. Slide the mounting bracket under the actuator. Ensure free movement of the slot at the base of the actuator. The bracket pin must be placed in the mid distance of the slot.
5. Fix the bracket to the ductwork with #8 self-tapping screws.

Wiring Diagrams

Models TBTF3000A & 3021A RBTF5000A & 3021A

3 wire / 2 position (ON-OFF)

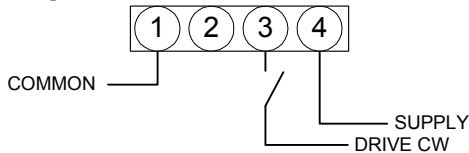

3 wire / 3 point floating

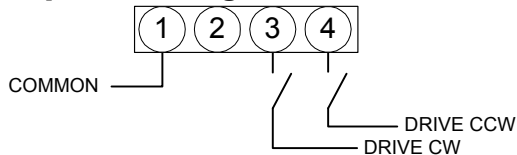

Models TBTF3060A & 3080A RBTF5060A & 3080A

2 wire / 2 position (ON-OFF)

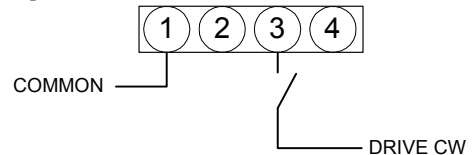

4 wire / 3 point floating

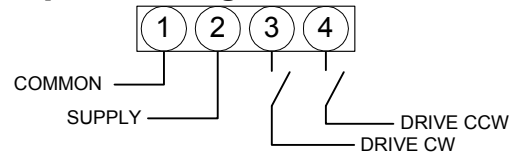

PC Board

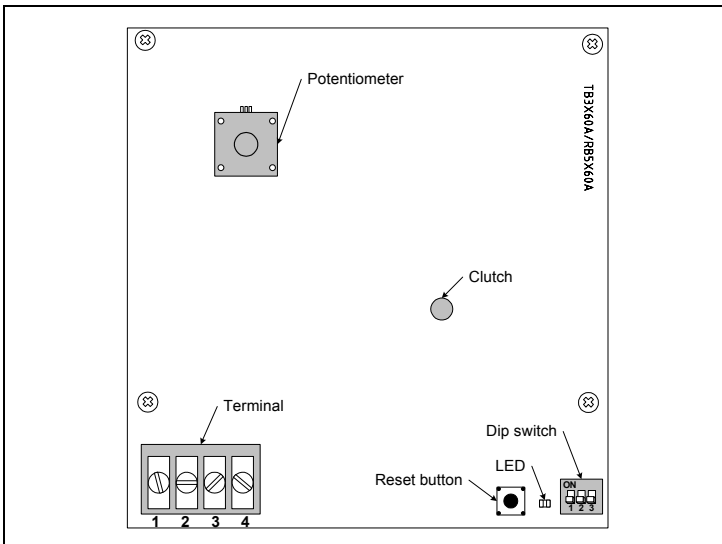

Dip switch settings

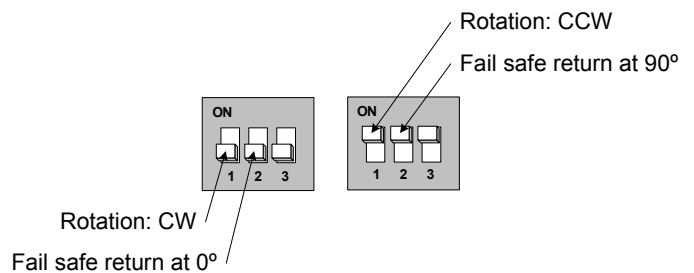

Stroke adjustment

To adjust the stroke, press and release the reset button to start the auto-stroke process. The LED should be illuminated.

- First option:
 The actuator will then travel in both directions to find it's limit.
 The LED will extinguish, the process is complete.
- Second option:
 When the desired end position is reached, press and release the reset button. The actuator will now return back to its original position. (you can also press and release the reset button when it reaches the original position)
 The LED will extinguish, the process is complete.