

**Feature:**

- Mounts easy on round & square shaft (with option -8).
- External clutch for manual adjustments.
- Maintenance free.
- Position indicator.
- Fail safe by *Enerdrive System*<sup>1</sup>
- Auxiliary switches (on model 1080).

*New Number*

MDTS1060	<i>DT060S</i>
MDTS1065	<i>DT065S</i>
MDTS1080	<i>DT080S</i>

Technical Data	MDTS1060 <i>DT060S</i>	MDTS1065 <i>DT065S</i>	MDTS1080 <i>DT080S</i>
<b>Auxiliary switches</b>	No	No	Yes (2)
<b>Feedback</b>	No	Yes	No
<b>Fail safe - Enerdrive</b>	Yes		
<b>Power consumption</b>	15VA Peak, 6VA		
<b>Control signal</b>	2 wire / 2 position, 4 wire / 3 point floating		
<b>Running time through 90°</b>	90 - 110 sec (Fail-safe 70-80 sec)		
<b>Torque</b>	50 in.lb. [5,6 Nm] at rated voltage (Fail-safe 35 in.lb. [3,9 Nm])		
<b>Power supply</b>	22 to 26 VAC or 28 to 32 VDC		
<b>Electrical connection</b>	18 AWG [0.8 mm <sup>2</sup> ] minimum		
<b>Inlet bushing</b>	2 inlet bushing of 5/8 in [15.9 mm] & 7/8 in [22.2 mm]		
<b>Angle of rotation</b>	0 to 90 degrees, mechanically adjustable (factory set with 90° stroke)		
<b>Direction of rotation</b>	Reversible, Clockwise (CW) or Counterclockwise (CCW) (factory set with CW direction)		
<b>Ambient temperature</b>	0°F to +122°F [-18° C to +50° C]		
<b>Storage temperature</b>	-22°F to +122°F [-30° C to +50° C]		
<b>Relative Humidity</b>	5 to 95 % non condensing.		
<b>Weight</b>	3 lbs. [1.4 kg]		

Warning: Do not press the clutch when actuator is powered

**Dimensions**

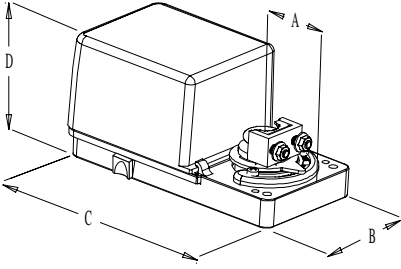

Dimension	Inches	Metric (mm)
<b>A</b>	1.50	38.1
<b>B</b>	3.26	82.8
<b>C</b>	6.60	167.5
<b>D</b>	3.01	76.4

**Caution**

We strongly recommend that all neptronic® products be wired to a separate transformer and that transformer shall service only neptronic® products. This precaution will prevent interference with, and/or possible damage to incompatible equipment.  
When multiple actuators are wired on a single transformer, polarity must be observed. Long wiring runs create voltage drop which may affect the actuator performance.

<sup>1</sup> Enerdrive System U.S.A. Patent #5,278,454



Mechanical installation

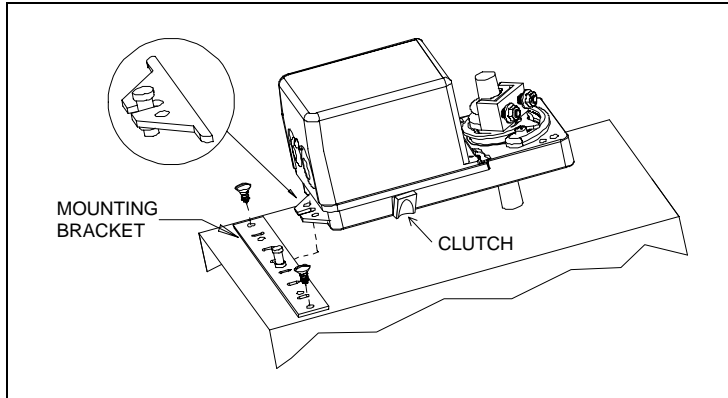

1. Manually close the damper blades and positioned the actuator at 0° or 90°.
2. Slide the actuator onto the shaft.
3. Tighten the nuts on the “U” bolt to the shaft with a 8mm wrench to a torque of 60 in.lb. [6,7 Nm].
4. Slide the mounting bracket under the actuator. Ensure free movement of the slot at the base of the actuator. The bracket pin must be placed in the mid distance of the slot.
5. Fix the bracket to the ductwork with #8 self-tapping screws.

Wiring Diagrams

2 wire / 2 position (ON-OFF)

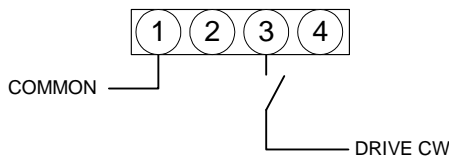

4 wire / 3 point floating

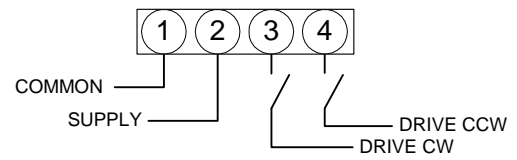

PC Board

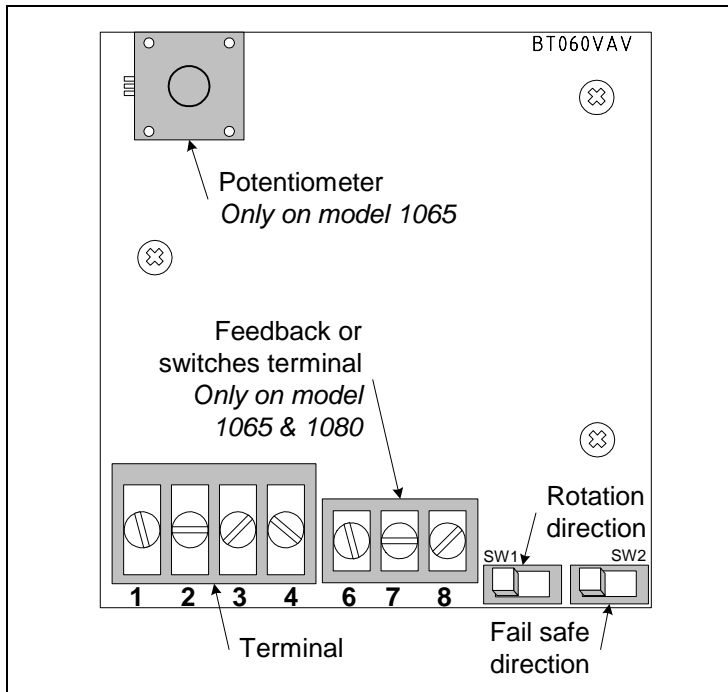

Dip switch settings

**Rotation direction (SW1)**



**Fail safe direction (SW2)**



Stroke adjustment

To adjust the stroke, move the adjustment screws at the desired position.