

## 3 Piece Tube Bore Ball Valves, 1/2" - 4" High Purity Applications



### Micro Pure Series

Model S7500  
Model S7700

Flow-Tek's Micro Pure Series ball valves have been specifically designed to meet the requirements of high purity applications. All valve bodies are investment cast CF3M (316L) Stainless Steel with 30-35 Ra internal surface finish as standard. Other grades of surface finishes, including electropolishing are available. Cavity fillers and purge ports are also available upon request.

**Tube Bore** The ball and end connections of all Micro Pure Series valves have the same I.D. dimension as the mating tube system. These valves offer smooth flow characteristics with minimal pressure drops.

**Processing** To prevent component contamination, Micro Pure Series valves can be solution cleaned, assembled and bagged to allow for use in high purity systems.

**Pressure Rating:**

Max: 1000 psi WOG  
(dependent on end connection selected)

**End Connections:**

- Quick Clamp
- Extended Tube End

End connections are interchangeable within the Micro Pure Series.



## Features



**Ball** Flow-Tek balls are precision machined and mirror finished for bubble-tight shut off and reduced operating torque.

**Seat** Flow-Tek's unique design incorporates a one-piece seat and seal that ensures bi-directional and bubble-tight sealing.

**Seat Selection** Optional seat materials are available to meet most applications, with the standard seat being Virgin PTFE. Optional seat designs, such as Cavity Fillers, are also available upon request.

**Body** 1/2"–4" valve bodies are investment cast and solution annealed for the highest quality and added strength. All body castings are marked with a foundry heat number for full traceability. The three piece body design offers many advantages, including installation flexibility, elimination of the need of flanges, and ease of in line or out of line servicing.

**Body Hinges** Two heavy duty body bolt hinges, throughout the entire size range, provide positive alignment of body to end connection during in-line servicing.

**End Connections** The Micro Pure Series features two standard interchangeable end connections – Quick Clamps for ease of installation and Extended Tube Ends for weld in place service.

**Secure Mount** A unique standard feature is an integrally cast top flange that ensures positive actuator mounting. Flow-Tek's Secure Mount eliminates unwanted actuator movement during high cycle or continuous duty applications. Actuation equipment can be easily and safely removed while the valve is under full line pressure. The Secure Mount through 2" valve sizes is in compliance with ISO 5211 bolting pattern standards.

**Handles** 1/2"–2" manually operated valves feature as standard a Safety Trigger to prevent accidental movement of the valve handle. The trigger locks the handle in the open or closed position. The handle lock can be overridden, if needed, with a small bolt through the handle in the release position. An oval handle is also available as an option.

**Padlock** A padlock can be added to secure the handle in position, preventing unwanted access. Available as standard on all valve sizes.

### Smart Stem Assemblies

Flow-Tek manufactures heavy duty, high quality stems. All Flow-Tek stems are internal entry and blowout proof for maximum safety. Micro Pure Series valves feature strong, large diameter stems with live-loaded, self-adjusting primary and secondary sealing. Utilizing belleville washers, the stem seal automatically adjusts to compensate for changes in temperature and normal wear. The assembly is secured by a saddle-type lock washer, preventing unthreading of stem nuts in high cycle automation applications.

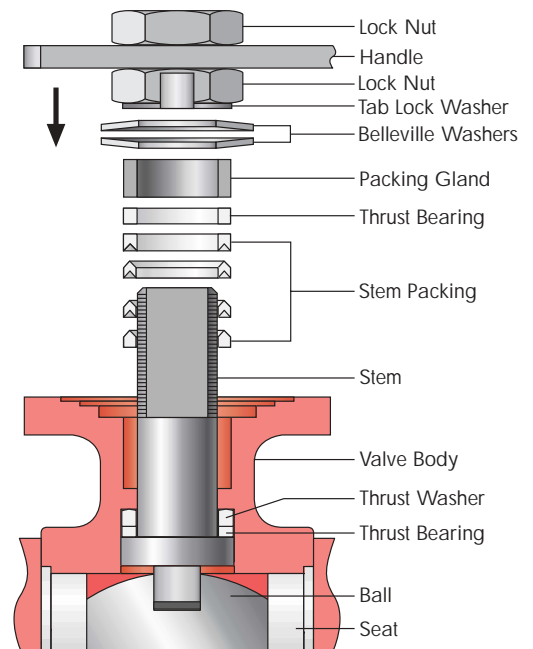

**Stem Seals** The Thrust Bearing and the Thrust Washer combine to provide the primary seal. An adjustable Stem Packing and an additional thrust bearing create a multiple secondary seal between the stem and body. The stem packing is also composed of PTFE providing high purity protection and high cycle life. This dual stem seal arrangement is a Flow-Tek exclusive.

**Double Lock Nut Design** Standard on the Micro Pure Series, the double lock nuts with tab lock washer allow handles to be easily and safely removed while the valve is under full line pressure.

# Specifications

## Valve Sizes 1/2" through 4"

Valve body and end connections are high quality investment cast and solution annealed. Body shell wall thickness complies with ASME/ANSI B16.34.

Valve stems are blow-out proof for maximum safety and comply with ASME/ANSI B16.34.

All standard materials of construction comply with FDA requirements.

## Pressure Ratings

Valve Body .....	1000 psi WOG
Steam Rating .....	150 psi WSP
Vacuum .....	0.02 mm Hg 0.02 Torr

## Pressure / Temperature

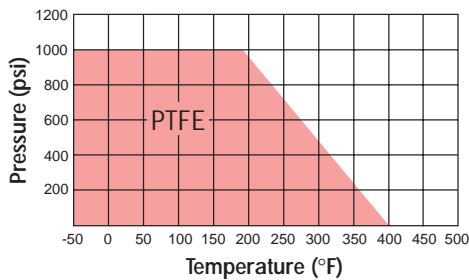

**Caution:** Do not subject these valves to thermal cycles exceeding 200°F.

## Surface Finishes

Grade	Ra (µin)	Electropolished
A	8 – 12	Included
B	15 – 20	Optional
C	20 – 25	Optional
D	30 – 35	—

**Example:** A 1" Tube End O.D. Valve with a 8 – 12 Ra Finish, Electropolished will read as follows: S7705-A-EP.

Flow-Tek offers the one piece seat/body seal, thrust washers, and soft material stem packing as recommended spare parts. These parts are available as a packaged repair kit.

## Components & Materials

### For Valve Sizes 1/2" through 2"

For 2 1/2" – 4" consult factory.

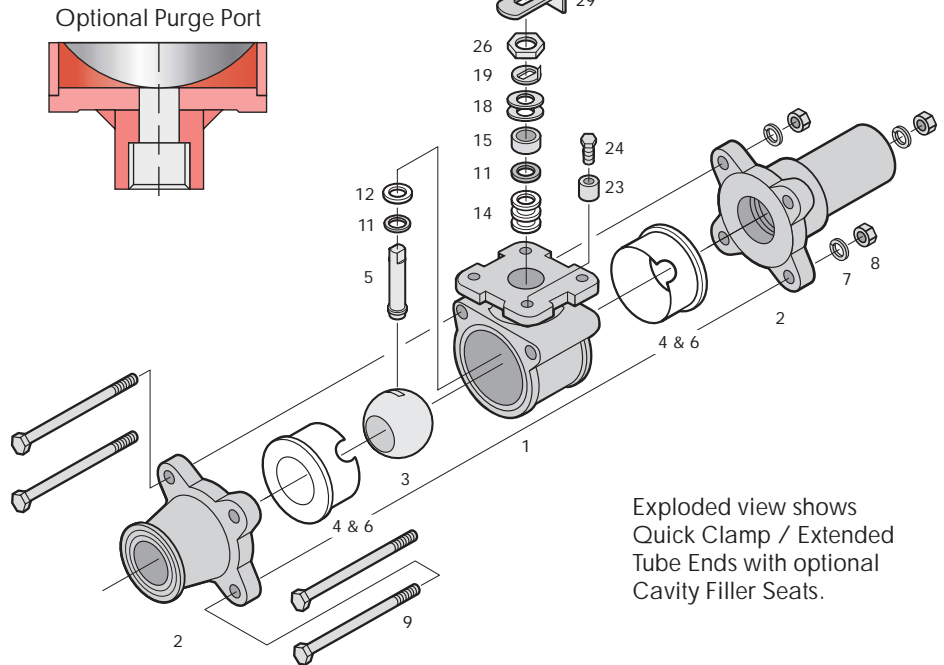

Exploded view shows Quick Clamp / Extended Tube Ends with optional Cavity Filler Seats.

Item	Name	Material	Qty.
1	Body	ASTM A351 Gr CF3M†	1
2	End Cap	ASTM A351 Gr CF3M†	2
3	Ball	ASTM A351 Gr CF3M†	1
4 & 6	Cavity Filler & Body Seal*	PTFE	2
5	Stem	ASTM A479 Type316	1
7	Spring Washer	SS304	4**
8	Body Nut	SS304	4**
9	Body Bolt	SS304	4**
11	Thrust Bearing	PTFE	2
12	Thrust Washer	PTFE	1
14	Stem Packing	PTFE	3
15	Packing Gland	SS304	1
18	Belleville Washer	SS301	2
19	Tab Lock Washer	SS304	1
23	Travel Stop Set Sleeve	SS304	1
24	Travel Stop Bolt	SS304	1
25	Handle	SS304	1
26	Lock Nut	SS304	2
28	Handle Sleeve	Vinyl	1
29	Locking Device	SS304	1

†Sizes 2-1/2, 3 and 4" are ASTM A351 Gr CF8M.

\*Standard valve has a One-piece seat and body seal. Cavity Filler and Body Seal are optional.

\*\*Quantity will be 6 for 3" and 4."

## DIMENSIONS, TORQUES & WEIGHTS

SIZE in mm	A1	A2	Port øB	øB1	C	C1	D	S7500 C <sub>V</sub>	S7700 C <sub>V</sub>	WEIGHT lbs./kg.	BOLT TORQUE lbs-ins./Nm	BREAK TORQUE lbs-ins./Nm	
												w/o Cavity Filler	w/ Cavity Filler
1/2 15	3.602 91.5	6.00 152.4	0.370 9.4	0.370 9.4	2.60 66	1.535 39	6.496 165	9.5	7.4	2 0.9	150 17	50 5.6	80 9
3/4 20	4.114 104.5	6.00 152.4	0.620 15.8	0.620 15.8	2.60 66	1.535 39	6.496 165	30	25	3 1.4	150 17	60 6.8	85 9.6
1 25	4.480 113.8	6.50 165.1	0.870 22.1	0.870 22.1	2.91 73.9	1.658 42	6.496 165	65	54	4 1.8	150 17	100 11.3	130 14.7
1½ 40	5.055 128.4	7.50 190.5	1.370 34.3	1.370 34.3	3.62 91.9	2.254 57.3	7.874 200	205	172	7 3.2	280 32	215 24	280 32
2 50	5.748 146	8.50 215.9	1.870 47.5	1.870 47.5	4.53 115.1	2.953 75	9.842 250	420	352	10 4.5	285 32.2	370 42	500 56
2½ 65	6.850 174	10.0 254	2.559 65	2.370 60.2	5.04 128	3.386 86	9.646 245	430	430	20 9.1	330 37	685 77	890 100
3 80	7.402 188	11.5 292.1	2.992 76	2.870 72.9	6.42 163.1	3.720 94.5	15.354 390	675	675	32 14.5	600 68	1500 169	1950 220
4 100	8.758 222.5	12.5 317.5	4.016 102	3.834 97.4	7.09 180.1	4.350 110.5	15.354 390	1110	1110	55 24.9	650 73	2000 226	2600 294

## SECURE MOUNT

SIZE ins	H	J	K	L	M	øP	U UNC
1/2 15	1.169 29.7	1.169 29.7	0.35 8.9	0.61 15.5	0.250 6.35	0.375 9.5	#10-24
3/4 20	1.169 29.7	1.169 29.7	0.35 8.9	0.61 15.5	0.250 6.35	0.375 9.5	#10-24
1 25	1.169 29.7	1.169 29.7	0.40 10.2	0.61 15.5	0.250 6.35	0.375 9.5	#10-24
1½ 40	1.392 35.4	1.392 35.4	0.51 13	0.80 20.3	0.315 8	0.438 11.1	1/4" -20
2 50	1.949 49.5	1.949 49.5	0.62 15.8	0.94 23.9	0.374 9.5	0.625 15.9	5/16" -18
2½ 65	2.840 72.1	2.840 72.1	0.82 20.8	1.22 31	0.472 12	0.750 19.1	5/16" -18
3 80	3.543 90	1.874 47.6	1.752 44.5	3.00 76.2	0.669 17	1.102 28	1/2" -13
4 100	3.543 90	1.874 47.6	1.752 44.5	3.00 76.2	0.669 17	1.102 28	1/2" -13

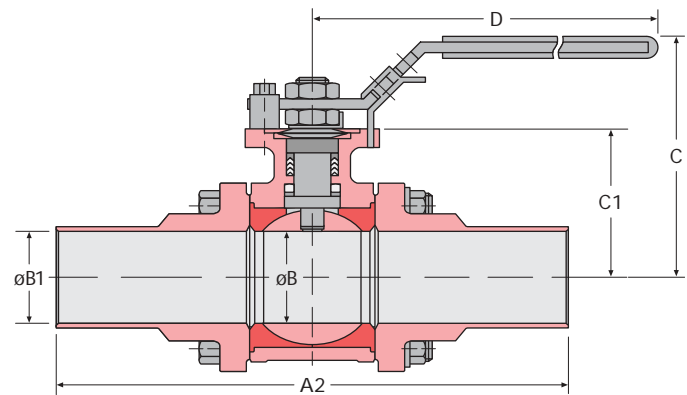

Extended Tube End Connections  
Model S7700

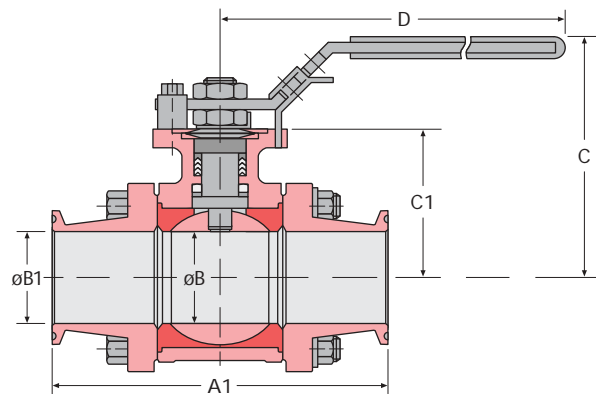

Quick Clamp End Connections  
Model S7500

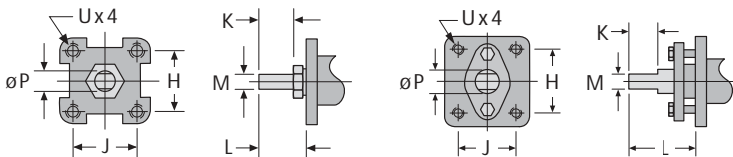

1/2" - 2" Valves

2 1/2" - 4" Valves

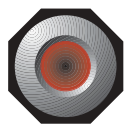

# Flow-Tek

A Subsidiary of BRAY INTERNATIONAL, Inc.  
11850 Tanner Road Houston, Texas 77041  
832.912.2300 Fax: 832.912.2301

www.flow-tek.com

All statements, technical information, and recommendations in this bulletin are for general use only. Consult Flow-Tek representatives or factory for the specific requirements and material selection for your intended application. The right to change or modify product design or product without prior notice is reserved.